

## MODEL ICM4 - SERIAL CONVERTER MODULE (RS232C/RS485)

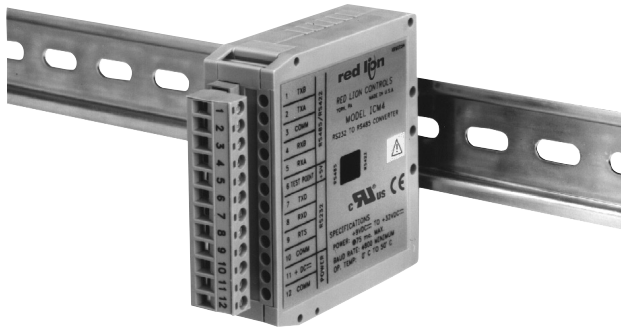

- *ALLOWS COMMUNICATIONS BETWEEN RS232 CONTROL EQUIPMENT AND PRODUCTS WITH RS485 SERIAL COMMUNICATIONS*
- *WIDE DC INPUT POWER RANGE (+9 to 32 VDC)*
- *HALF DUPLEX (RS485) AND FULL DUPLEX (RS422)*
- *LED INDICATION FOR RXD, TXD, and POWER*
- *UNIVERSAL MOUNTING FOOT FOR DIN RAIL INSTALLATION*



UL Recognized Component,  
 File # E179259



### DESCRIPTION

The ICM4 Serial Converter Module provides the capability of interfacing equipment with RS485 serial communications to equipment with RS232 communications. Data format of the RS232 and RS485 equipment must be the same.

For full duplex (RS422), the DIP switch on the side of the module must be in the RS422 position. For half duplex (RS485), the DIP switch must be in the RS485 position. In half duplex mode, the RS485 driver is enabled using the leading edge of the first character transmitted (RXD input). After the last character transmits, the converter waits one character time (at 9600 baud) to disable the RS485 driver.

There are 3 LED's that can be viewed from the front of the converter module. A green power LED indicates power is on, a red RS232 TXD LED flashes when the module is transmitting, and a green RS232 RXD LED flashes when the module is receiving.

An external DC power source (+9 to 32 VDC) is required to power the ICM4. The external power source and serial communications connections are made via a 12 position removable terminal block located on the front of the module.

The unit is equipped with a universal mounting foot for attachment to standard DIN style mounting rails, including top hat profile rail according to EN50022 - 35 x 7.5 and 35 x 15, and G profile rail according to EN50035 - G32.

### SAFETY SUMMARY

All safety related regulations, local codes and instructions that appear in the manual or on equipment must be observed to ensure personal safety and to prevent damage to either the instrument or equipment connected to it. If equipment is used in a manner not specified by the manufacturer, the protection provided by the equipment may be impaired.

**CAUTION: Risk of Danger.**  
 Read complete instructions prior to installation and operation of the unit.

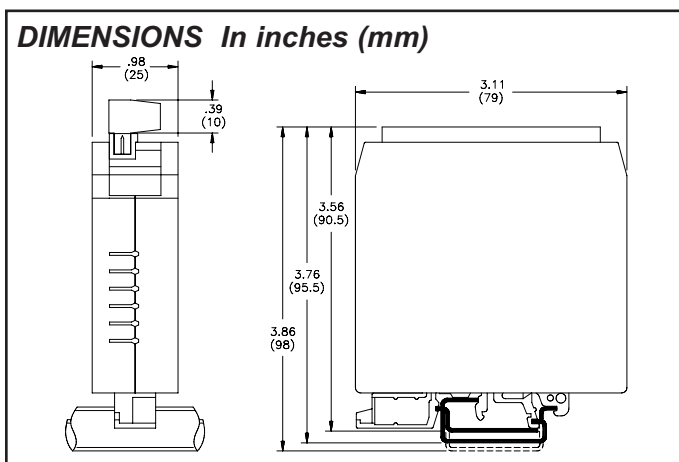

### SPECIFICATIONS

- POWER:** +9 to 32 VDC @ 75 mA maximum. Above 26 VDC, derate max. operating temperature to 40°C. Power supply must be Class 2 or SELV rated.
- RS232 VOLTAGES:**
  - Receive Data Pin:** ± 30 VDC max.
  - Mark Condition:** ≤ 0.8 VDC
  - Space Condition:** ≥ 2.4 VDC
  - Transmit Data Pin:**
    - Mark Condition:** -8 VDC (typ.)
    - Space Condition:** +8 VDC (typ.)
- RS485 VOLTAGES:**
  - Differential Output Voltage:** ± 5 VDC max. under no load
  - Differential Input Voltage:** ± 5 VDC max.
  - Mark Condition:** ≤ -0.2 VDC
  - Space Condition:** ≥ +0.2 VDC
  - RS485 Drive Capability:** Up to 32 RS485 receivers connected in parallel.
  - RS485 Drive Disable Time:** 4 msec. max.
- MAXIMUM CABLE LENGTH:**
  - RS232:** 50 feet
  - RS485:** 4000 feet
- BAUD RATE:** 9600 min., 19200 max.
- CERTIFICATIONS AND COMPLIANCES:**

#### SAFETY

UL Recognized Component, File #E179259, UL3101-1, CSA C22.2 No. 1010-1  
 Recognized to U.S. and Canadian requirements under the Component Recognition Program of Underwriters Laboratories, Inc.  
 IEC EE CB Scheme Test Certificate # US/5141A/UL,  
 CB Scheme Test Report # 01ME11540-0702001  
 Issued by Underwriters Laboratories, Inc.  
 IEC 61010-1, EN 61010-1: Safety requirements for electrical equipment for measurement, control and laboratory use, Part 1.

#### ELECTROMAGNETIC COMPATIBILITY

##### Immunity to EN 50082-2

|                                  |              |  |
|----------------------------------|--------------|--|
| Electrostatic discharge          | EN 61000-4-2 | Level 2; 4 Kv contact<br>Level 3; 8 Kv air                   |
| Electromagnetic RF fields        | EN 61000-4-3 | Level 3; 10 V/m<br>80 MHz - 1 GHz                            |
| Fast transients (burst)          | EN 61000-4-4 | Level 4; 2 Kv I/O<br>Level 3; 2 Kv power                     |
| RF conducted interference        | EN 61000-4-6 | Level 3; 10 V/rms<br>150 KHz - 80 MHz                        |
| Simulation of cordless telephone | ENV 50204    | Level 3; 10 V/m<br>900 MHz ± 5 MHz<br>200 Hz, 50% duty cycle |

##### Emissions to EN 50081-1

|                 |          |                   |
|-----------------|----------|-------------------|
| RF interference | EN 55022 | Enclosure class B |
|-----------------|----------|-------------------|

Refer to EMC Installation Guidelines for additional information.

## SPECIFICATIONS (Cont'd)

### 7. ENVIRONMENTAL CONDITIONS:

**Operating Temperature Range:** 0 to 50°C. Derate max. operating temperature to 40°C above 26 VDC.

**Storage Temperature:** -40 to +75°C

**Operating and Storage Humidity:** 85% max. relative humidity (non-condensing) from 0 to 50°C

**Altitude:** Up to 2000 meters

8. **CONSTRUCTION:** Case body is green, high impact plastic. Installation Category I, Pollution Degree 2.

9. **MOUNTING:** Standard DIN rail top hat (T) profile rail according to EN50022- 35 X 7.5 and 35 X 15

10. **WEIGHT:** 3.2 oz. (90.7 g)

## EMC INSTALLATION GUIDELINES

Although this unit is designed with a high degree of immunity to ElectroMagnetic Interference (EMI), proper installation and wiring methods must be followed to ensure compatibility in each application. The type of electrical noise, source or coupling method into the unit may be different for various installations. In extremely high EMI environments, additional measures may be needed. Cable length, routing and shield termination are very important and can mean the difference between a successful or a troublesome installation. Listed below are some EMC guidelines for successful installation in an industrial environment.

- DC power to the unit should be relatively clean and within the specified limits. Connecting power to the unit from circuits that power inductive loads that cycle on and off, such as contactors, relays, motors, etc., should be avoided. This will reduce the chance of noise spikes entering the DC power connection and affecting the unit.
- The shield (screen) pigtail connection should be made as short as possible. The connection point for the shield depends somewhat upon the application. Listed below are the recommended methods of connecting the shield, in order of their effectiveness.
  - Connect the shield only at the unit to earth ground (protective earth).
  - Connect the shield to earth ground at both ends of the cable, usually when the noise source frequency is above 1 MHz.
  - Connect the shield to common of the unit and leave the other end of the shield unconnected and insulated from earth ground.
- Never run Signal cables in the same conduit or raceway with AC power lines, conductors feeding motors, solenoids, SCR controls, and heaters, etc. The cables should be run in metal conduit that is properly grounded. This is especially useful in applications where cable runs are long and portable two-way radios are used in close proximity or if the installation is near a commercial radio transmitter.
- Signal cables within an enclosure should be routed as far away as possible from contactors, control relays, transformers, and other noisy components.
- In extremely high EMI environments, the use of external EMI suppression devices, such as ferrite suppression cores, is effective. Install them on Signal cables as close to the unit as possible. Loop the cable through the core several times or use multiple cores on each cable for additional protection.

Install line filters on the power input cable to the unit to suppress power line interference. Install them near the power entry point of the enclosure. The following EMI suppression devices (or equivalent) are recommended:

Ferrite Suppression Cores for signal cables:

Fair-Rite # 0443167251 (RLC #FCOR0000)

TDK # ZCAT3035-1330A

Steward #28B2029-0A0

Line Filters for input power cables:

Schaffner # FN610-1/07 (RLC #LFIL0000)

Schaffner # FN670-1.8/07

Corcom #1VR3

**Note:** Reference manufacturer's instructions when installing a line filter.

- Long cable runs are more susceptible to EMI pickup than short cable runs. Therefore, keep cable runs as short as possible.

## SIDE VIEW OF ICM4

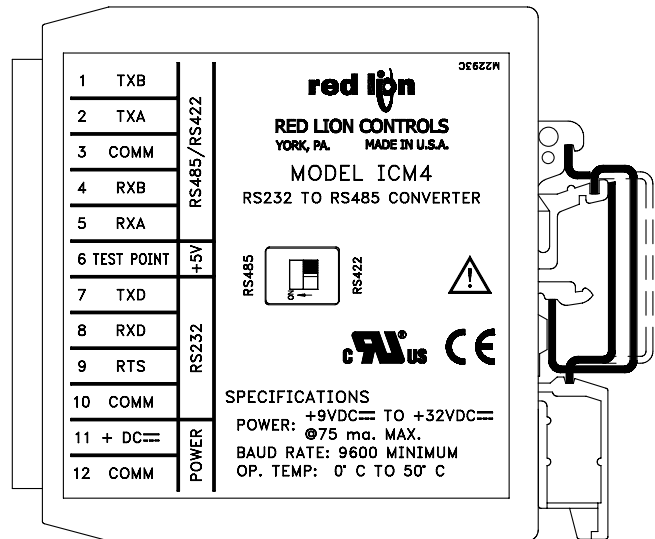

## TYPICAL RS422 CONNECTIONS

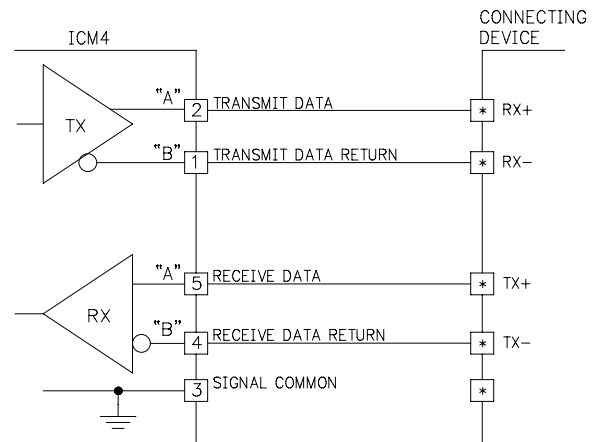

### Notes:

- Connect shield drain wire to earth ground.
- Place DIP switch on the side of the ICM4 in the 422 position.
- RS422 polarity: Terminal "A" is negative with respect to Terminal "B" in the mark (logic 1) condition.

## TYPICAL RS485 CONNECTIONS

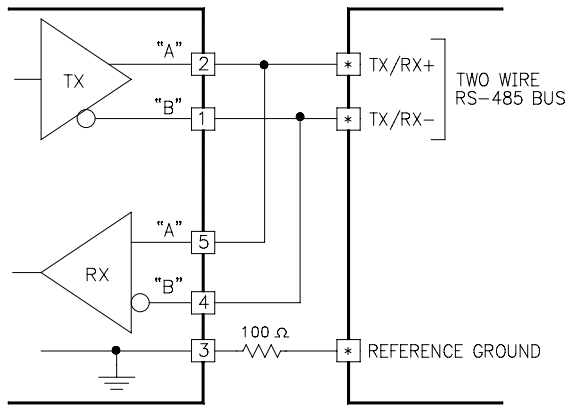

### Notes:

1. Connect shield drain wire to earth ground.
2. Place DIP switch on the side of the ICM4 in the 485 position.
3. The transmit and receive data lines of the ICM4 should be wired together.

## TYPICAL RS232 CONNECTIONS

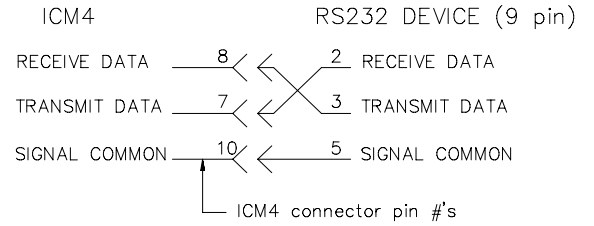
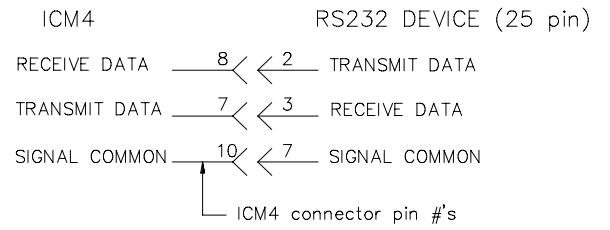

## TYPICAL CONNECTION FOR SINGLE UNIT

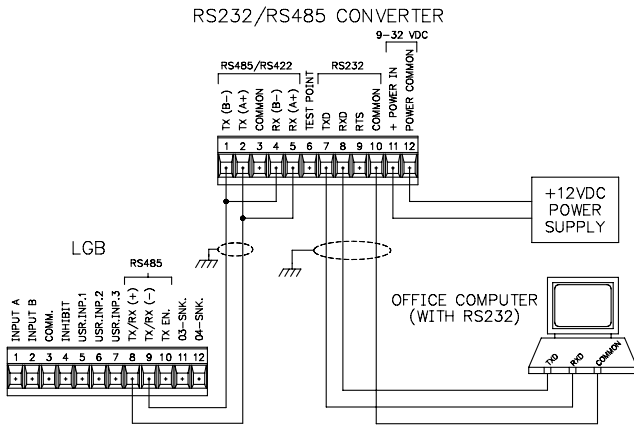

## TYPICAL CONNECTION FOR MULTIPLE UNITS

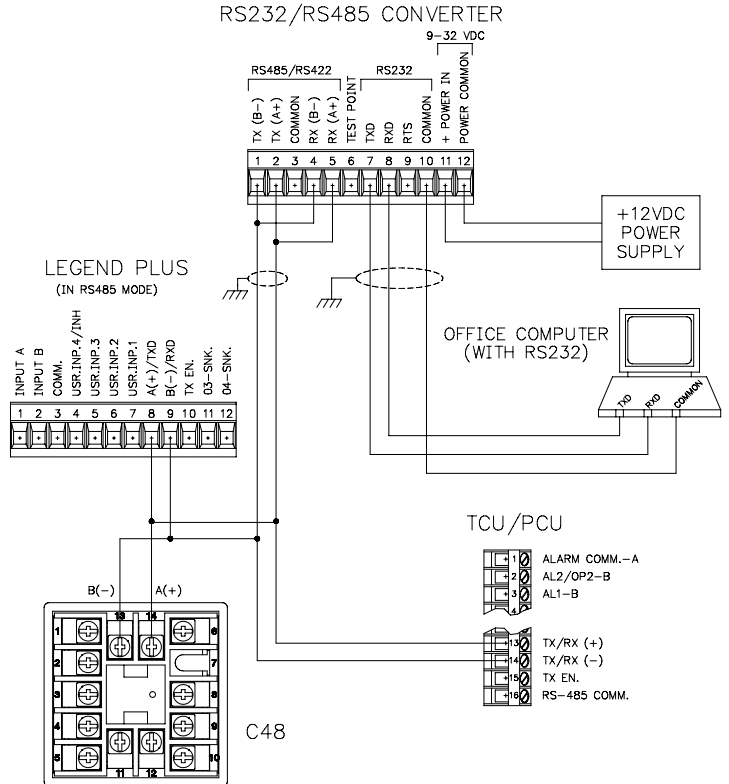

## INSTALLATION

The unit is equipped with a universal mounting foot for attachment to standard DIN style mounting rails, including G profile rail according to EN50035 - G32 , and top hat (T) profile rail according to EN50022 - 35 x 7.5 and 35 x 15. The unit should be installed in a location that does not exceed the maximum operating temperature and provides good air circulation. Placing the unit near devices that generate excessive heat should be avoided.

### G Rail Installation

To install the ICM4 on a "G" style DIN rail, angle the module so that the upper groove of the "foot" catches under the lip of the top rail. Push the module toward the rail until it snaps into place. To remove a module from the rail, push up on the bottom of the module while pulling out away from the rail.

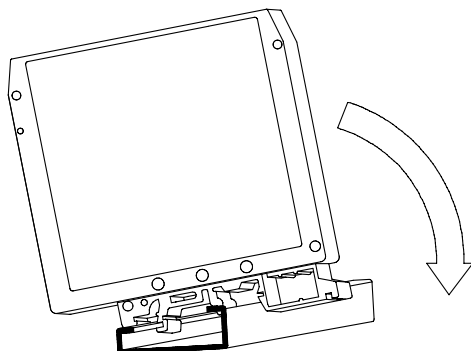

### T Rail Installation

To install the ICM4 on a "T" style rail, angle the module so that the top groove of the "foot" is located over the lip of the top rail. Push the module toward the rail until it snaps into place. To remove a module from the rail, insert a screwdriver into the slot on the bottom of the "foot", and pry upwards on the module until it releases from the rail.

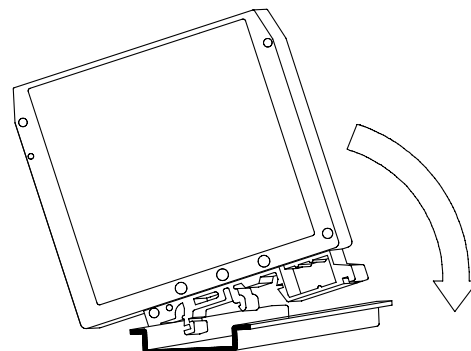

## ORDERING INFORMATION

| MODEL NO. | DESCRIPTION                  | PART NUMBER |
|-----------|------------------------------|-------------|
| ICM4      | RS232/RS485 Converter Module | ICM40030    |

## TROUBLESHOOTING

For further technical assistance, contact technical support at the appropriate company numbers listed.

## LIMITED WARRANTY

The Company warrants the products it manufactures against defects in materials and workmanship for a period limited to two years from the date of shipment, provided the products have been stored, handled, installed, and used under proper conditions. The Company's liability under this limited warranty shall extend only to the repair or replacement of a defective product, at The Company's option. The Company disclaims all liability for any affirmation, promise or representation with respect to the products.

The customer agrees to hold Red Lion Controls harmless from, defend, and indemnify RLC against damages, claims, and expenses arising out of subsequent sales of RLC products or products containing components manufactured by RLC and based upon personal injuries, deaths, property damage, lost profits, and other matters which Buyer, its employees, or sub-contractors are or may be to any extent liable, including without limitation penalties imposed by the Consumer Product Safety Act (P.L. 92-573) and liability imposed upon any person pursuant to the Magnuson-Moss Warranty Act (P.L. 93-637), as now in effect or as amended hereafter.

No warranties expressed or implied are created with respect to The Company's products except those expressly contained herein. The Customer acknowledges the disclaimers and limitations contained herein and relies on no other warranties or affirmations.

Red Lion Controls  
20 Willow Springs Circle  
York PA 17402  
Tel +1 (717) 767-6511  
Fax +1 (717) 764-0839

Red Lion Controls BV  
Basicweg 11b  
NL - 3821 BR Amersfoort  
Tel +31 (0) 334 723 225  
Fax +31 (0) 334 893 793

Red Lion Controls AP  
31, Kaki Bukit Road 3,  
#06-04/05 TechLink  
Singapore 417818  
Tel +65 6744-6613  
Fax +65 6743-3360